

PULSE CONTROLLED TRISTEPPER C 900

GB	OWNER'S MANUAL	P. 2-7
D	BETRIEBSANLEITUNG	S. 8-13
F	MODE D'EMPLOI	P. 14-19
NL	HANDLEIDING	P. 20-25
I	MANUALE D'USO	P. 26-31
E	MANUAL DEL USUARIO	P. 32-37
S	BRUKSANVISNING	S. 38-43
FIN	KÄYTTÖOHJE	S. 44-49



REMARKS AND WARNINGS

PLEASE READ THIS OWNER'S MANUAL THROUGH CAREFULLY BEFORE ASSEMBLING, USING AND SERVICING THE DEVICE! FOLLOW THE INSTRUCTIONS DESCRIBED IN THIS MANUAL CAREFULLY.

THE EQUIPMENT HAS BEEN DESIGNED FOR HOME USE. THE TUNTURI WARRANTY APPLIES ONLY FOR FAULTS AND MALFUNCTIONS IN HOME USE.

Before connecting the device to a power source make sure the voltage is correct. The voltage is marked on the step-down transformer (either 230 V or 115 V). Do not connect the device directly to the mains supply.

NOTE ABOUT THE EQUIPMENT

- * The device must always be unplugged during any assembly or service work.
- * Check the transformer for the correct voltage.
- * Always unplug the device from the power source after you have finished your workout.
- * Although the device operates with a 12 V protective voltage all service and repair work are recommended to be carried out by a person qualified to service electromechanical appliances according to the legislation of your country.
- * The magnet caliper of the magnetic brake forms an extremely powerful magnetic field which may damage the mechanism of a watch or the magnetic identification tape of a credit or cash card if they come into immediate contact with the magnets. Never attempt to detach or remove the magnet caliper of the magnetic brake.

NOTE ABOUT YOUR HEALTH

- * **Before you start any training, consult a physician to check your state of health.**
- * If you experience nausea, dizziness or other abnormal symptoms while exercising, stop your workout at once and consult a physician.
- * Warm up slowly by stepping at a slow pace. Increase gradually until you reach the desired workout pace. Before completing a workout session, slow your pace gradually to a slow step, allowing your heart rate to decrease to normal before stopping and stepping off the device. To avoid muscular pain, begin and end each workout by stretching and warming up and cooling down.
- * The TARGET PULSE -programme is based on pulse measurement, i.e. the device regulates the resistance according to the measured pulse. Since an erratic measurement can cause a risk to the user it is most important to follow the instructions and warnings described in this manual about pulse measurement. Follow your pulse also during the training. If you notice interference in the measurement, stop your workout at once.

NOTE ABOUT THE EXERCISING ENVIRONMENT

- * Place the device on a firm, level surface.
- * Make sure that the exercising environment has adequate ventilation. To avoid catching cold, do not exercise in a draughty place.

NOTE ABOUT USING THE EQUIPMENT

- * Parents or others responsible for children should note that children's natural playfulness and curiosity may lead to situations and behaviour for which the device is not designed. If children are allowed to use the device, they should be supervised and taught to use the device properly, keeping in mind the child's physical and mental development and their personality.
- * Before you start using the device, make sure that it functions correctly in every way. Do not use a faulty device.
- * As the stepper is not covered from below, make sure that there are no small metal objects such as screws, coins etc. near or under the stepper. The magnetic brake mechanism might draw small metal objects into the mechanism, thus causing possible danger.
- * In heavy or long-term use, the device may shed dust or oil. It is therefore advised to place the device on a protective base.
- * Only one person may use the device at a time.
- * Place the device on a firm, level surface.
- * Hold the handlebar for support when getting on or off the device. Keep at least one hand on the handlebar when exercising.
- * Always keep your hands well away from moving parts.
- * Wear appropriate clothing and shoes when exercising.
- * Never operate the device with sidecovers removed.
- * **Do not attempt any servicing or adjustment other than those described in this manual.**
- * The device is not recommended for persons weighing over 110 kg.

THE FIGURES REFERRED TO IN THE TEXT ARE IN THE BACK FOLD.

1. ASSEMBLY

Before assembling the device, insure all parts are present (fig. 1):

A	Main mast assembly
B	Support legs (2)
C	Tie rods (2)
D	Feet (2)
E	Handlebar support tube
F	Meter mount
G	Meter
H	Transmitter belt
I	Transformer (12 V)
J	Hard ware kit

If you notice that a part is missing, contact the dealer and give the model (TriStepper 900), serial number and spare part number from the spare part list in the back of the manual.

The package includes a silicate bag for absorbing moisture during storage and transportation.

Once the device and all its parts have been unpacked, assemble as follows (left, right, front and rear are seen from the exercising position):

1.1. ATTACH THE SUPPORT LEGS

Position the main mast assembly on the floor so that the TriStepper label is facing up. Screw the left leg tube into the main mast as shown (fig. 2), being careful to keep the leg tube in line. **N.B. Do not force.** If resistance is felt initially, unscrew and start again. Hand tighten the leg firmly. Install the right leg in the same manner.

1.2. ATTACH THE TIE RODS

Place the hooked end of a tie rod into the left hole at the bottom of the main mast (fig. 3). Gently slide the tie rod bracket into the end of the left tube while simultaneously inserting the threaded end of the tie rod into the tie rod bracket. Slide the bracket with the rod into the tube as far as possible, making sure the bracket is at the correct angle to the tie rod.

Secure the tie rod with a flat washer and locking nut. Tighten the nut with the flat wrench supplied. Repeat for the right tie rod.

1.3. ATTACH THE FEET

The feet are labeled "L" and "R" (for left and right). Slide each foot onto its respective leg, making sure the tie rod fits into the bottom of the slot (fig. 4). Tilt the TriStepper back into the upright position.

1.4. ATTACH THE HANDLEBAR

Align the holes on the base of the handlebar to those on the top of the mast, making sure the handlebar end caps are pointing forward. Secure the handlebars with four Allen screws and split lock washers. Tighten screws with the hex wrench (fig. 5).

1.5. ATTACH THE METER

Feed the wires from the meter through the meter mount and push the meter into place on the meter mount (fig. 6). Connect the wires and snap the meter mount over the handlebars, making sure the tongue on the handlebar mount fits into the corresponding groove on the meter mount (fig 7). **N.B. Be careful not to damage the wire.**

To secure the meter, remove carefully the meter and the protective paper from the two-sided adhesive tape on the meter mount. Push the meter back into place. **N.B. Be careful not to damage the wire.**

1.6. PLUG IN THE TRANSFORMER

Plug the transformer into the connector in the lower left hand corner of the side of the pulley cover and then to the wall socket (fig. 8). **N.B. Make sure the wire does not run under the device.**

2. USE

Working out using a stepper is excellent aerobic exercise, the principle being that the exercise should be suitably light, but of long duration. Aerobic exercise is based on improving the body's maximum oxygen uptake, which in turn improves endurance and fitness. The ability of the body to burn fat as a fuel is directly dependent on its oxygen-uptake capacity. Aerobic exercise should above all be pleasant. You should perspire, but you should not get out of breath during the workout. You must, for example, be able to speak and not just pant while pedalling.

You should exercise at least three times a week, 30 minutes at a time, to reach a basic fitness level. Maintaining this level requires a few exercise sessions each week. Once the basic condition has been reached, it is easily improved, simply by increasing the number of exercise sessions. Exercise efficiency can be measured by monitoring the pulse.

Exercise is always rewarding for weight loss, because it is the only way of increasing the energy spent by the body. This is why it is always worthwhile to combine regular exercise with a healthy diet.

The feet of the TriStepper 900 move independently of each other. **This means that as the resistance is decreased, the tempo will need to be increased and the step length shortened, in order to exercise and avoid the pedals descending too far with the users weight.** With fast tempo and small steps the work out is more efficient: the pulse is faster and energy consumption increases. The higher the columns of dots on the display, the more efficient the work out is.

N.B. Keep your head up and neck straight in order to avoid strain on your neck, shoulders and back. Keep also your back straight. Make sure that your feet are centered on the foot pedals and that your hips, knees, ankles and toes are facing forward. Keep your body weight centered over your lower body regardless to whether you lean forward or stand upright.

3. METER

3.1. METER KEYS AND FUNCTIONS

1. MANUAL

Allows you to set your effort level with the arrow keys during the workout. These manually made programmes can be saved in the memory of the meter (see 3.3. MEMORY FUNCTION).

2. INTERVAL

This programme changes the effort levels during your workout. The display shows the programme and the changes in effort. You can choose a profile to your liking by pushing the INTERVAL button repeatedly.

3. TARGET PULSE

This programme allows you to preset your pulse level, i.e. the resistance is regulated so that your pulse remains at the requested level. The set value can be changed also during the workout.

4. HILL

This programme increases resistance gradually during the whole workout.

5. RESET

Resets all values.

6. ENTER

Approves set values and user parameters.

7. MEMORY

Saves and opens manual programmes (user 1-4).

8. SCAN

Allows selection of Scan function or a certain display.

9. ARROW KEYS

Used for setting values. In the manual function used for increasing or decreasing resistance.

10. TIME / EFFORT

This display alternates between elapsed time (countdown) and effort in watts (or effort level in INTERVAL programme).

11. TOTAL STEPS / STEPS/MIN

This display alternates between the total number of steps taken and the rate.

12. KCAL / PULSE

This display alternates between approximate energy consumption in kilocalories and pulse.

3.2. OPERATING THE METER

N.B. Protect the meter from direct sunlight, as it may damage the liquid crystal display. Do not expose the meter to water or severe impacts, as these may also damage the meter.

The meter switches on automatically when the device is

connected to the power source. The display gives out a short beep after which all the functions are at zero.

If you do not use the device for more than 5 minutes, the meter automatically switches off.

3.2.1. MANUAL FUNCTION

1. **Select the manual function by pressing the MANUAL key** after the meter has been switched on or after pressing the RESET key. **Press the ENTER key.** You can change your programme selection any time before you press ENTER.
2. The **TIME display** in the upper right-hand corner of the display will start to flash. **Choose the desired duration of workout** (1-90 minutes in steps of 5 minutes) by using the arrow keys. However, you can also exercise for a shorter or longer period than you have chosen. After having set duration, **press the ENTER key.**
3. The **weight display** in the lower right-hand corner starts to flash. The left-hand side display reads KG ->. **Enter your weight** (default value 70 kg). The meter counts your approximate energy consumption during the workout according to your weight. After having entered your weight, **press the ENTER key** again.
4. **Begin your workout.** You can adjust the effort level with the arrow keys, and the column of dots in the left-hand display indicate the chosen effort level.

By pressing the SCAN key the right-hand side displays automatically scan different values every 6 seconds. You can also switch off the scan function by pressing the SCAN key, if you want to follow only the effort, steps/minute and pulse displays, for example.

The topmost display shows either **time countdown** or **effort in watts**. The middle display shows either **total steps** or **rate in steps/minute**. The lowest display indicates either **approximate energy consumption in kilocalories** or **pulse**.

When the chosen workout time has elapsed, the meter will maintain the effort level and continues counting the training values, so you can continue your workout without stopping if you so wish.

Manually made programmes can be saved in the memory of the meter (see 3.3. MEMORY FUNCTION).

3.2.2. INTERVAL PROGRAMME

1. **Select the INTERVAL programme by pressing the INTERVAL key** after the meter has been switched on or after pressing the RESET key. **Press ENTER key.** You can change your programme selection any time before you press ENTER. The various effort levels are indicated by green dots on the display on the left. By pressing the INTERVAL

key repeatedly you get the display to show different effort profiles and you can choose the one best suited for you by pressing the ENTER key.

2. The **TIME display** in the upper right-hand corner of the display will start to flash. **Choose the desired duration of workout** (1-90 minutes in steps of 5 minutes) by using the arrow keys. The device uses this value to calculate the duration of the different effort levels during the programme. However, you can also exercise for a shorter or longer period than you have chosen. After having set duration, **press ENTER key**.
3. The **EFFORT display** in the meter's upper right-hand corner starts to flash. **Select the desired effort level**, from 1 up to 9 (default value 5). If you are just beginning, choose a low effort level from 1 to 5. If you are very fit, select a high effort level from 6 to 9. **N.B.** You can change your effort level during the workout with the arrow keys. After having set the effort level, **press ENTER key**.
4. The **weight display** in the lower right-hand corner starts to flash. The left-hand side display reads KG ->. **Enter your weight** (default value 70 kg). The meter counts your approximate energy consumption during the workout according to your weight. After having entered your weight, **press the ENTER key** again.
5. **Begin your workout.**

By pressing the SCAN key the right-hand side displays automatically scan different values every 6 seconds. You can also switch off the scan function by pressing the SCAN key, if you want to follow only the effort, steps/minute and pulse displays, for example.

The topmost display shows either **time countdown** or **effort in watts**. The middle display shows either **total steps** or **rate in steps/minute**. The lowest display indicates either **approximate energy consumption in kilocalories** or **pulse**.

The flashing dot in the left-hand display shows the present effort level in the workout programme.

When the chosen workout time has elapsed, the meter will maintain the effort level and continues counting the training values, so you can continue your workout without stopping if you so wish.

3.2.3. TARGET PULSE PROGRAMME

Exercise in different pulse ranges affects the body in different ways. For example, **exercise of long duration within a pulse range that is about 50-60 % of the maximum pulse burns fat**, or helps you lose weight, whereas **exercise in a range that is about 70-80 % of the maximum develops the heart and respiratory system, and overall endurance**, i.e. it improves your condition. If you don't know your own maximum pulse rate you can use the following formulas as a guideline:

WOMEN: APPROX. MAXIMUM PULSE = 226 - AGE
MEN: APPROX. MAXIMUM PULSE = 220 - AGE

However, it is advisable to **make sure by consulting your doctor**.

The **TARGET PULSE** programme enables training at the requested pulse level. The programme requires measurement of pulse.

1. **Select the TARGET PULSE programme by pressing the TARGET key** after the meter has been switched on or after pressing the RESET key.
2. The **PULSE display** in the lower right-hand corner of the display will start to flash. **Set the desired pulse value** (beats/min) by using the arrow keys. **N.B.** The preset value can be changed during the training. You can e.g. begin your training with a lower, warm up level and increase your effort level after a while by increasing the pulse value. After having set the pulse value, **press the ENTER key**.
3. The **TIME display** in the upper right-hand corner of the display will start to flash. **Choose the desired duration of workout** (1-90 minutes in steps of 5 minutes) by using the arrow keys. After having set duration, **press the ENTER key**.
4. The **weight display** in the lower right-hand corner starts to flash. The left-hand side display reads KG ->. **Enter your weight** (default value 70 kg). The meter counts your approximate energy consumption during the workout according to your weight. After having entered your weight, **press the ENTER key** again.
5. **Begin your workout.**

Follow your pulse during the training and especially the small light, the so called heart indicator next to the PULSE text. The light should flash in time with your heartbeat. If the indicator begins to function in a disturbing fashion (e.g. additional beats or unnormal fluctuations), the pulse measurement is not functioning properly. Stop your workout and make sure that you have followed all the instructions described in this manual about pulse measurement (see 3.4. MEASURING PULSE).

If the stepping effort seems too strenuous or easy, change the preset pulse value by using the arrow keys.

By pressing the SCAN key the right-hand side displays automatically scan different values every 6 seconds. You can also switch off the scan function by pressing the SCAN key, if you want to follow only the effort, steps/minute and pulse displays, for example.

The topmost display shows either **time countdown** or **effort in watts**. The middle display shows either **total steps** or **rate in steps/minute**. The lowest display indicates either **approximate energy consumption in kilocalories** or **pulse**.

The flashing dot in the left-hand display shows the present effort level.

When the chosen workout time has elapsed, the meter will maintain the pulse level and continues counting the training values, so you can continue your workout without stopping if you so wish.

3.3. MEMORY FUNCTION

The meter enables saving of 4 manually made programmes to its memory (see 3.2.1. MANUAL FUNCTION).

The meter has four preprogrammed training programmes of different length and effort levels. If you wish to use one of these programmes, move to RUNNING THE PROGRAMMES.

3.3.1. SAVING THE PROGRAMMES

When you wish to save a manually made programme in the memory of the meter, **press the MEMORY key** after your workout session. The display in the lower right-hand corner reads USr 1 (= user 1). **Choose the desired memory location** (USr 1, USr 2, USr 3, USr 4) by using the arrow keys. After having chosen the location, **press the ENTER key**. Your programme is now saved in the memory of the meter.

3.3.2. RUNNING THE PROGRAMMES

1. When you want to use an earlier saved programme, **press the MEMORY key** after the meter has been switched on or after pressing the RESET key.
2. **Choose the desired programme** with the arrow keys. **Press the ENTER key**.
3. The time display in the upper right-hand corner of the display will start to flash. **Choose the desired duration of workout** (1-90 minutes in steps of 5 minutes) by using the arrow keys. **Press the ENTER key**.
4. The **weight display** in the lower right-hand corner starts to flash. The left-hand side display reads KG ->. **Enter your weight** (default value 70 kg). **Press the ENTER key**.
5. **Begin your workout.**

N.B. If you wish, you can adjust the effort level with the arrow keys during the training. If you want to save these changes in the memory, press the MEMORY key after your workout and choose the desired memory location. Press ENTER after making your selection.

3.4. MEASURING PULSE

This device has a built in pulse receiver which is **compatible with a POLAR telemetric pulse transmitter**. The transmitter is automatically included.

Reliable pulse measurement is achieved with a telemetric device, in which the electrodes of the transmitter fastened to

the chest transmit the pulses from the heart to the meter by means of an electromagnetic field.

If you want to measure your pulse this way during your workout, **moisten the grooved electrodes** on the transmitter belt with saliva or water.

Fasten the transmitter just below the chest with the elastic belt, firmly enough so that the electrodes remain in contact with the skin, but not so tight that normal breathing is prevented.

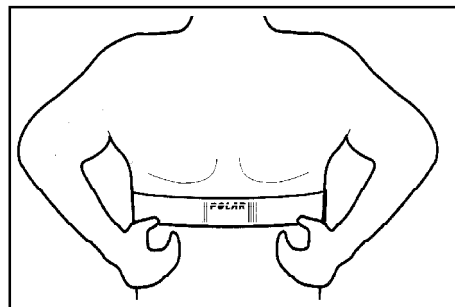
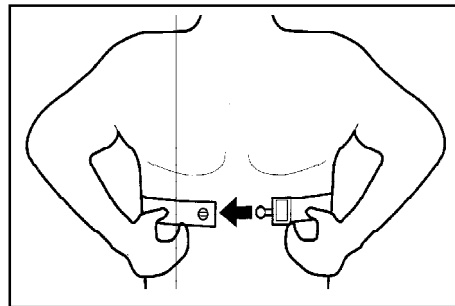
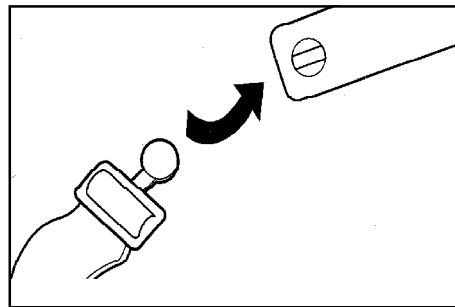
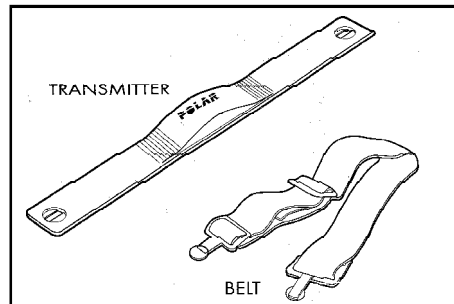

The transmitter automatically transmits the pulse reading to the meter up to a distance of about 1 m.

If you wear the transmitter and belt over a light shirt, **moisten the shirt slightly at the points where the electrodes touch the shirt.**

The pulse value is displayed in the lower right-hand display of the meter.

Follow your pulse during the training and especially the heart indicator light next to the PULSE text. The light should flash in time with your heartbeat. If the indicator begins to function in a disturbing fashion (e.g. additional beats or abnormal fluctuations), the pulse measurement is not functioning properly.

REMARKS ON TELEMETRIC PULSE MEASUREMENT

N.B. IF YOU HAVE A HEART PACEMAKER, YOU MAY USE THE PULSE MEASUREMENT TRANSMITTER ONLY ON A PHYSICIAN'S APPROVAL!

If the electrode surfaces are not moist, the pulse reading will not appear on the display. **If the electrodes are dry, they must be moistened again. Allow the electrodes to warm up properly** to ensure accurate pulse measurement.

If there are **several telemetric pulse measurement devices** next to each other, the **distance between them should be at least 1.5 m.** Similarly, if there is only one receiver and **several transmitters in use, only one person with a transmitter should be within transmission range.**

The transmitter is switched to an active state only when it is being used for measurement. Sweat and other moisture can, however, keep the transmitter in an active state and waste battery energy. Therefore it is important to **dry the electrodes carefully after use.**

4. MAINTENANCE

The TriStepper 900 requires very little maintenance. Check, however, from time to time the condition of the rubber retraction bands. Tilt the stepper on its side to inspect the rubber bands at the bottom of the stepper. If the bands are worn or frayed, contact your local TUNTURI representative to have the bands replaced.

To avoid premature wear on the chain mechanism and to lower the noise level of the stepper, it is recommended to lubricate the pedal chains with vaseline.

Check from time to time that all fastening screws and nuts are tight. Clean the stepper with a damp cloth. Do not use solvents.

Although the device operates with a 12 V protective voltage we recommend the following adjustment to be carried out only by a person qualified to service electro-mechanical appliances according to the legislation of your country.

In spite of continuous quality control, individual defects and malfunctions may occur due to individual components. It is in most cases unnecessary to take the whole device for repair, as it is usually sufficient to replace the defective part.

If you notice any defects or malfunctions in the device during use, contact your dealer immediately. Always give the serial number of your device!

5. TRANSPORT AND STORAGE

The stepper is easy to move by pushing along on the built-in transportation wheels. Unplug the transformer from the power source and from the connector in the lower left hand corner of the side of the pulley cover. Take hold of the handlebar from the back, tilt the stepper forward and push along the floor on the wheels at the bottom of the main mast.

To prevent malfunctioning of the stepper, store it in a dry place with as little temperature variation as possible, protected against dust.

6. DIMENSIONS

Length	87 cm
Height	141 cm
Width	86 cm
Weight	41 kg

All TUNTURI models are designed to meet the electro-magnetic compatibility directive, EMC, and are affixed with the CE conformity marking.

The information presented in this manual is given in good faith and as accurately as possible. However, anyone who uses this information in installing, using or servicing the device does so at their own risk.

Due to continuous programme of product development we reserve the right to change specifications without notice.

TUNTURI PULSE CONTROLLED TRISTEPPER C 900

LIST FOR RECYCLING / INDEX FÜR MATERIALENTSORGUNG

- A = Plastic, Thermoplast
Kunststoff, Thermoplast
- B = Paper, Carton
Papier, Pappe
- C = Metal / Metall
- D = Electronics / Elektronik
- E = Batteries / Batterien
- F = Other / Sonstiges

This list will help you to sort out the different components for recycling purposes.

Dieser Index soll Ihnen die Zuordnung der Rohstoffe bei einer späteren Entsorgung erleichtern.

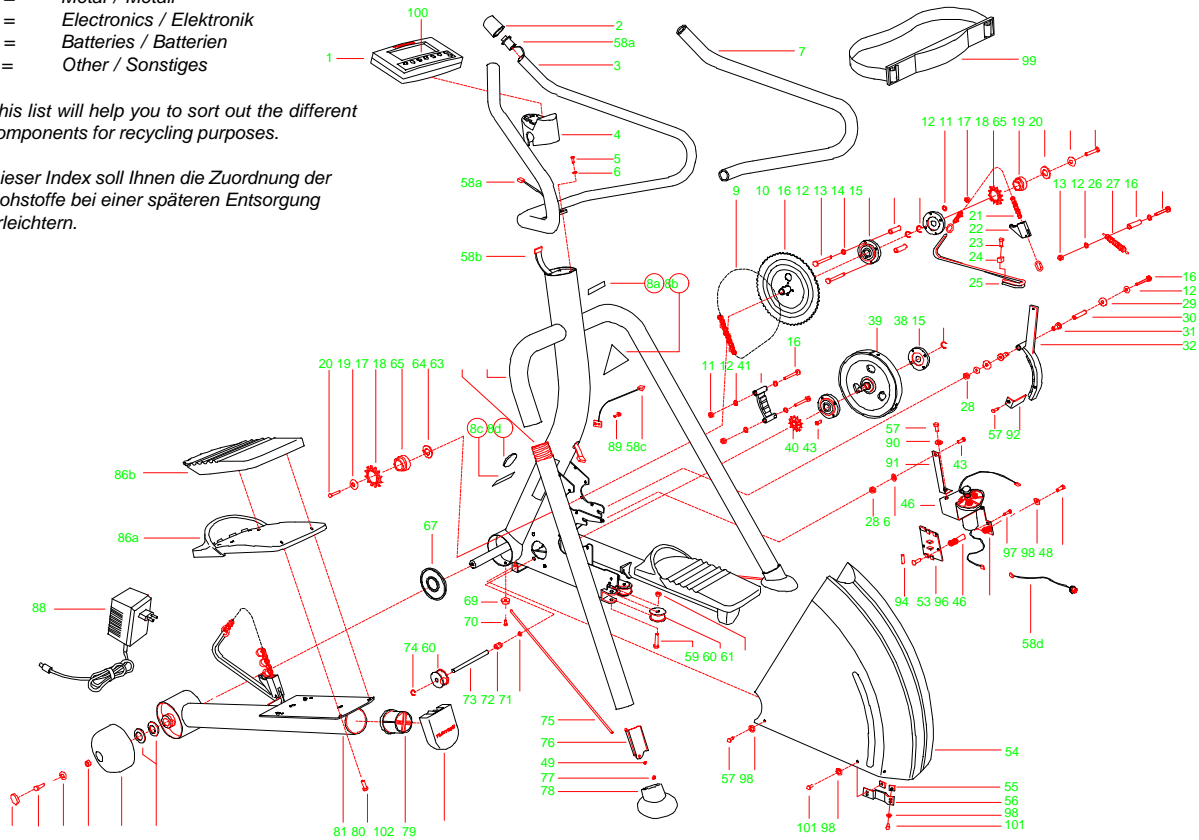

Ref. no	Part no											
1	233 7011 (incl. 58)	D	27	72 0711 670 1	C	58	403 7011	D	84	60 08 016 03	C	
-	173 7009		28	61 0610	A/C		(incl. 58b-d)		85	533 7031	A	
2	533 7024	A	29	62 0624 10	C	58a	403 7014	D	86	363 7002	A	
3	203 7007 (incl. 2,7)	C	30	523 1009	C	59	653 7015	C		(incl. 86a, 86b)		
4	503 7003	A	31	533 1010	A	60	533 8004	A	87	523 102 71	C	
5*	60 06 016 33	C	32	373 7005	C	61	61 0810 N	A/C	88	403 7010	D	
6*	62 0612 16	C	37	60 05 010 21	C	63	103 7029	C		USA 120V		
7	213 7007	A	38	523 8001	A/C	64	103 7010	C	-	403 7009	D	
8	423 7037	E	39	303 7001	C	65	653 2002	A	-	GB 120 V		
	(incl. 8a-8d)			(incl. 15, 38, 40)		67	533 7036	A	-	403 7008	D	
9	253 7002	C	40	263 7003	A	68	62 2535 05	C		EUR 230V		
10	263 7005 (incl. 13,15)	C	41	373 7002	C	69	533 7025	A	89	653 0062	D	
C			43	60 06 016 37	C	70	653 5003	C	90	63 05 6798JP	C	
11	61 0601	C	44	373 1019	C	71	62 0817 16	C	91	501017	C	
12	63 06 6798AZ	C	45	60 03 006 21	C	72	533 4002	A	92	373 1020	C	
13	523 7011	C	46	503 7004	C	73	343 7007	C	93	403 1040	C	
14	72 0711 447 1	C	-	403 1037	A/C	74	673 600 86	C	94	403 1043	D	
15	673 601 90	C		(incl. 41,45-47,51,53, 93-97)		75	103 7009	C	95	683 402	A	
16	60 06 080 02	C	47	403 7012	D	76*	503 7002	C	96	503 7008	C	
17	263 2004	C	48	60 05 016 33	C	77*	61 0501	C	97	652 1701	C	
18	373 8003 (incl. 17)	C	49*	62 0511 10	C	78	533 7018	A	98	62 051515	C	
19	653 7021	C	51	60 05 008 35	C	-	533 7023	A	99	403 0015	A/D	
20	60 06 010 03	C	53	403 1039	D	79	533 7017	A	100	233 71010	F	
21	253 7003	C	54	173 7007 LH, RH	A	80	653 7020	C	-	553 7002	A/C	
22	533 7032	A	55	653 1003	C	81	103 7025	C		Tool set		
23	60 08 020 39	C	56	503 7006	C	-	103 7026	C	-	553 7003	A/C	
24	693 7001	C	57	60 05 012 21	C	82	533 7014	A		Hardware kit (incl. *)		
25	443 7002	E				83	62 0824 20	C				
26	643 8001	C										

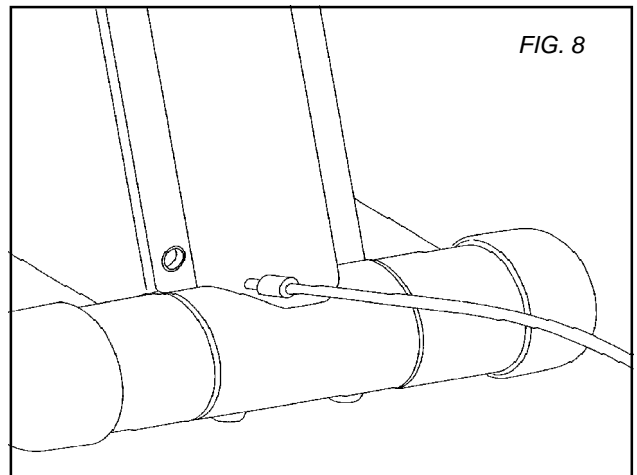
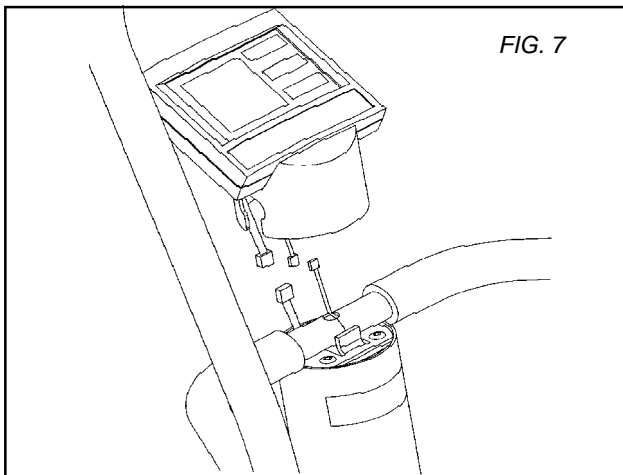
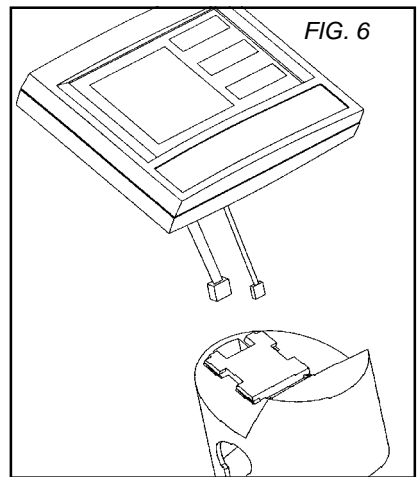
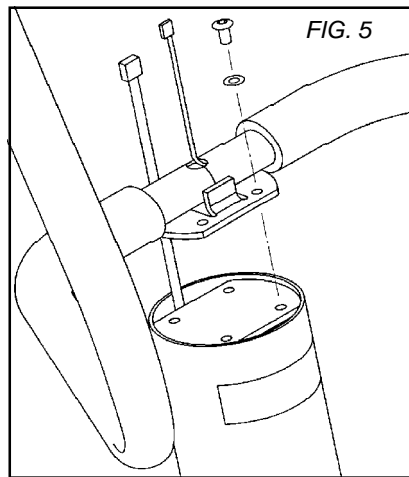
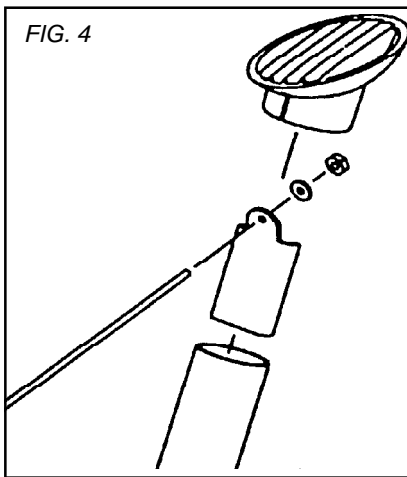
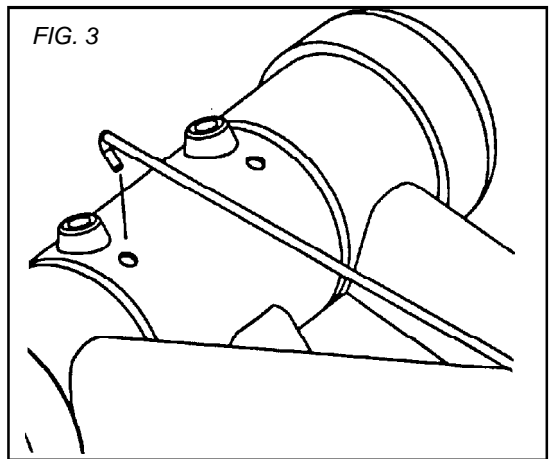
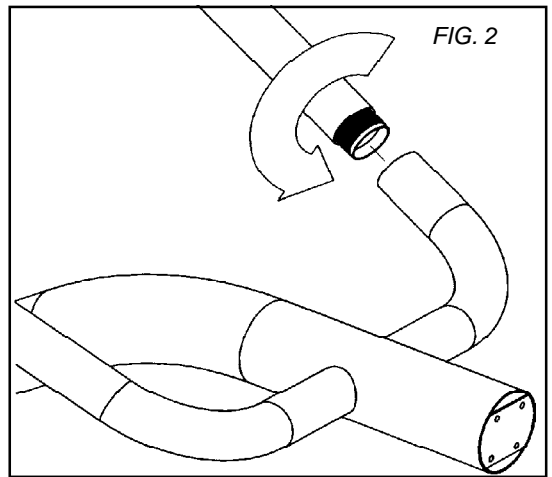
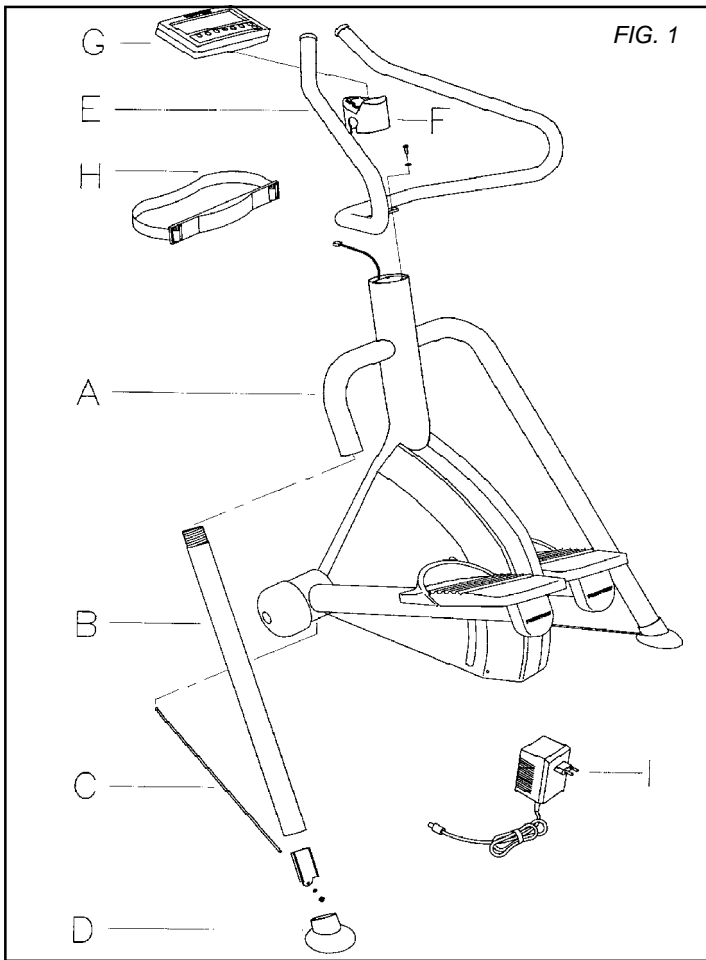

TUNTURIPYÖRÄ OY
P.O. Box 44
FIN-20521 Turku FINLAND
Tel. +358-2-2603 111
Fax +358-2-2603 323

<http://www.tunturi.com>
[email: fitness.mail@tunturi.com](mailto:fitness.mail@tunturi.com)